

SERIES 50 ANCHOR TABLE

CONFIG.	FRAME WIDTH	FRAME HEIGHT	NUMBER OF ANCHORS			DESIGN	DESIGN
			ACROSS HEAD & SILL	ACROSS JAMB	ACROSS HOOK STRIP	PRESSURE NEG.	PRESSURE POS.
XX	6' 6'	80.00 96.00	12 12	10 12	8 9	-50.00 -50.00	+50.00 +50.00
XX	8" 8'	80.00 96.00	16 16	10 12	8 9	-50.00 -50.00	+50.00 +50.00
XXX	9' 9'	80.00 96.00	18 18	10 12	8 9	-50.00 -50.00	+50.00 +50.00
XXX	12' 12'	80.00 96.00	24 24	10 12	8 9	-50.00 -50.00	+50.00 +50.00
XXXX	12' 12'	80.00 96.00	24 24	10 12	8 9	-50.00 -50.00	+50.00 +50.00
XXXX	16' 16'	80.00 96.00	30 30	10 12	8 9	-50.00 -50.00	+50.00 +50.00

NOTES:

- (1) THIS PRODUCT IS DESIGNED TO COMPLY WITH THE 2004 FLORIDA BUILDING CODE. UP TO AND INCLUDING THE 2007 SUPPLEMENT AND THE 2007 FLORIDA BUILDING CODE.
- (2) SHIM AS REQ'D AT EACH SET OF INSTALLATION ANCHORS USING LOAD BEARING SHIMS. MAX. ALLOWABLE SHIM STACK TO BE 1/4". USE SHIMS WHERE SPACE GREATER THAN 1/16" IS PRESENT.
- (3) DOOR MATERIAL : 6063-T5 ALUMINUM.
- (4) 3/16" DIA. CONCRETE SREW ANCHORS MUST BE OF SUFFICIENT LENGTH TO ACHIEVE A MIN. EMBEDMENT OF 1 1/4" INTO CONCRETE OR MASONRY FOR 1 X WOOD BUCK OR A MIN. EMBEDMENT OF 1 1/4" INTO SOLID WOOD FOR 2 X BUCK OR WOOD FRAMED OPENINGS (GREATER THAN 1 3/8" THICK).
- (5) MAX. ALLOWABLE SPACING OF 3/16" DIA. CONCRETE SCREWS, WITHIN 5-1/2" FROM EACH CORNER, 13" ACROSS HEAD & SILL, 17" ALONG JAMBS AND 11" ON HOOK STRIP.
- (6) ALL FACTORY APPLIED HOLES IN FRAME MEMBERS NOT DESIGNATED FOR CONCRETE SCREW ANCHORS SHOULD BE FILLED WITH #12 SCREWS OF SUFFICIENT LENGTH TO ACHIEVE A MIN. EMBEDMENT OF 5/8" INTO WOOD BUCK.
- (7) USE LATEX CAULK OR EQUIVALENT FOR PERIMETER SEAL AROUND EXTERIOR OF DOOR.
- (8) IF EXACT DOOR SIZE IS NOT LISTED IN ANCHOR CHART, USE THE NEXT SIZE LARGER DOOR FOR ANCHOR QUANTY.
- (9) FOR POCKET DOOR SIZES, USE CLOSEST BY-PASS DOOR SIZE TO SIZE OF FINISHED OPENING.
- (10) JAMB / SILL CORNERS AND ALL ANCHORS TO BE SEALED WITH SMALL JOINT SEAM SEALANT.
- (11) ALL INSTALLATION ANCHORS MUST BE MADE OF A CORROSION RESISTANT MATERIAL OR COATING.
- (12) NOT ALL CONFIGURATIONS LISTED ON ANCHOR CHART ARE SHOWN ON THIS DRAWING. HOWEVER, INSTALLATION SECTION A-A, B-B & D-D APPLY TO ALL CONFIGURATIONS.

NOTES ON ANCHOR CALCULATIONS:

- (1) CALCULATIONS DERIVED FROM TESTED UNIT, TEST REPORT # NCTL-210-3220-1C, NCTL-210-3112-1A
- (2) TESTED UNIT WAS "XXXX", 192" x 96", USING 9/16" (14mm) GLASS CONSISTING OF TWO 1/4" (35MM) EXTERIOR LAYERS OF HEAT STRENGTHENED GLASS AND A .090 (2.286MM) PVB INTERLAYER.
- (3) THE QUANTITY OF ANCHORS ARE FOR EACH SIDE, NOT TOTAL QUANTITY.
- (4) MAX. SPACING AT HEAD OR SILL CORNER IS 5". SPACING IS WITH ANCHORS IN PAIRS
- (5) MAX. SPACING AT JAMB CORNER IS 5-1/2". SPACING IS WITH ANCHORS IN PAIRS
- (6) MAX. SPACING ACROSS HEAD OR SILL IS 13". SPACING IS WITH ANCHORS IN PAIRS
- (7) MAX. SPACING ACROSS JAMBS IS 17". SPACING IS WITH ANCHORS IN PAIRS
- (8) MAX. SPACING ACROSS HOOK STRIP IS 11".

WINDOW CRAFTSMEN, INC. 6031 CLARK CENTER AVE. SARASOTA, FLORIDA 34238		
TITLE: SLIDING GLASS DOOR SERIES 50 IMPACT ANCHOR TABLE AND NOTES		
ENGINEER: MARK A. SMITH	DRAWN BY: MAS	DATE: 12/18/08
DISCIPLINE: CIVIL	SCALE: N.T.S.	DWG. NO. WCF-SGD007
FL. REG. NO.: 55511	REV. LETTER: B	SHEET 1

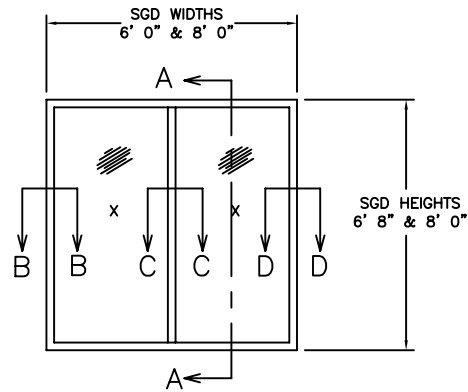

2 PANEL SLIDING GLASS DOOR
XX CONFIGURATION

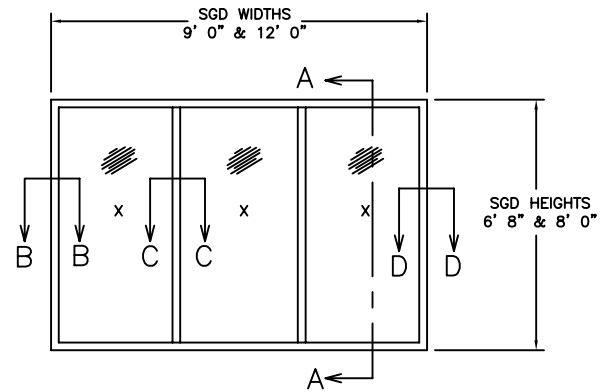

3 PANEL SLIDING GLASS DOOR
XXX CONFIGURATION

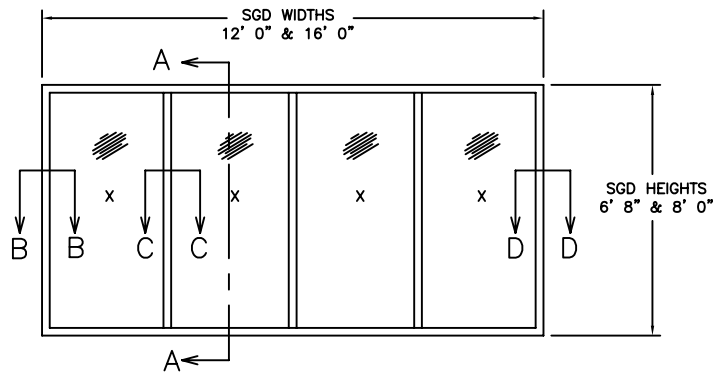

4 PANEL SLIDING GLASS DOOR
XXXX CONFIGURATION

FOR INSTALLATION DETAILS AND
SECTIONS A-A, B-B, C-C AND D-D SEE SHEETS 3, 4, AND 5

WINDOW CRAFTSMEN, INC. 6031 CLARK CENTER AVE. SARASOTA, FLORIDA 34238		
TITLE: SLIDING GLASS DOOR 50 IMPACT 2, 3 & 4 PANEL ELEVATIONS		
ENGINEER: MARK A. SMITH	DRAWN BY: MAS	DATE: 12/18/08
DISCIPLINE: CIVIL	SCALE: N.T.S.	DWG. NO. WCI-SGD007
FL. REG. NO.: 55511	REV. LETTER:	SHEET 2

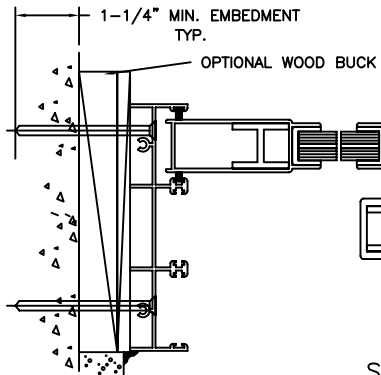

SECTION B-B

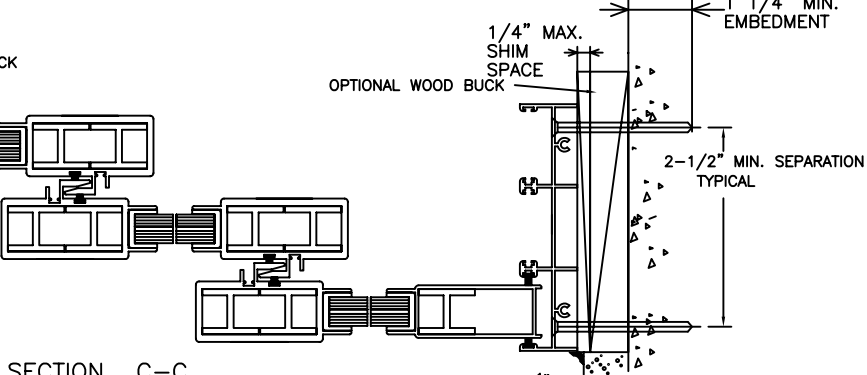

SECTION C-C
EXTERIOR INTERLOCK
SERIES 50

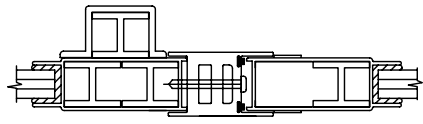

ASTRAGAL
SERIES 50

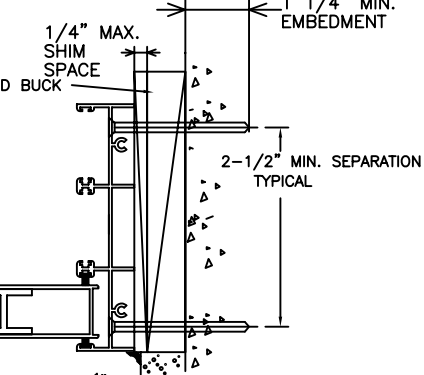

SECTION D-D

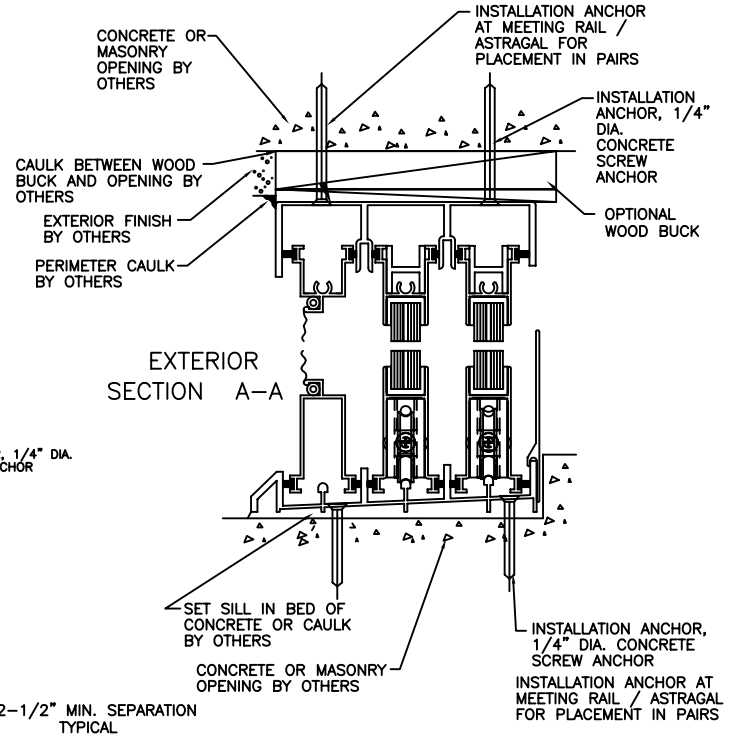

EXTERIOR
SECTION A-A

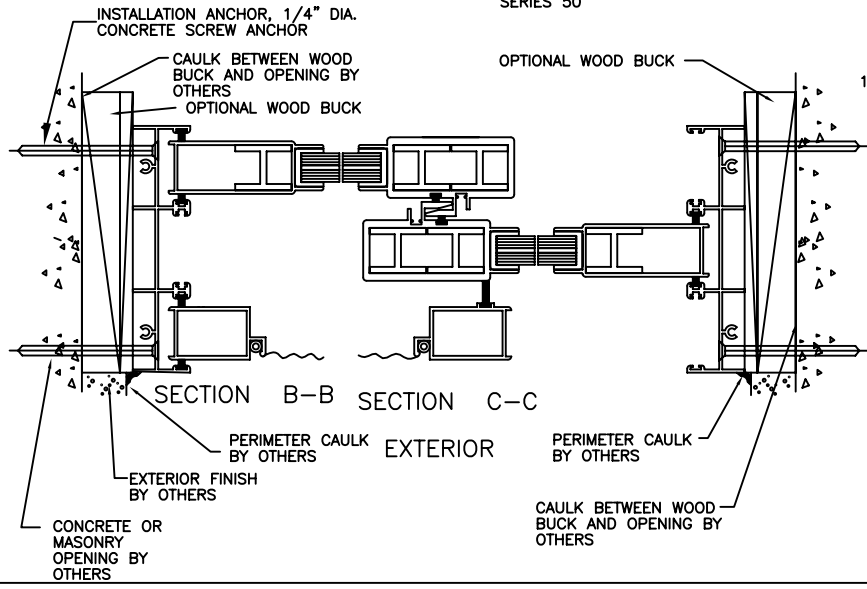

SECTION B-B SECTION C-C
EXTERIOR

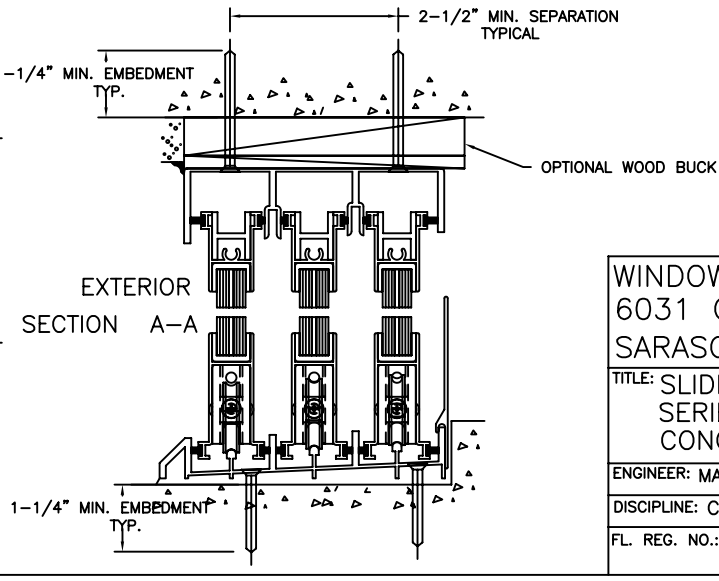

EXTERIOR
SECTION A-A

NOTE: WOOD FRAMING NOT REQUIRED

WINDOW CRAFTSMEN, INC. 6031 CLARK CENTER AVE. SARASOTA, FLORIDA 34238		
TITLE: SLIDING GLASS DOOR SERIES 50 IMPACT CONCRETE INSTALLATION DETAILS		
ENGINEER: MARK A. SMITH	DRAWN BY: MAS	DATE: 12/18/08
DISCIPLINE: CIVIL	SCALE: N.T.S.	DWG. NO. WCI-SGD007
FL. REG. NO.: 55511	REV. LETTER: A	SHEET 3

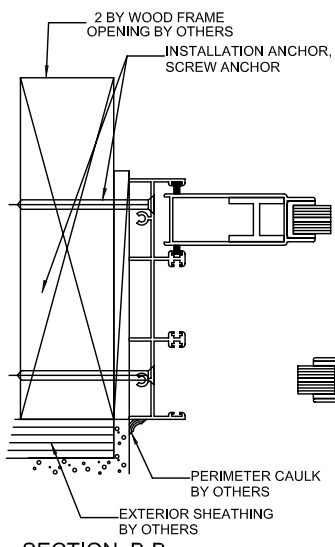

SECTION B-B

TYPICAL DETAIL AT 2 BY WOOD FRAMING

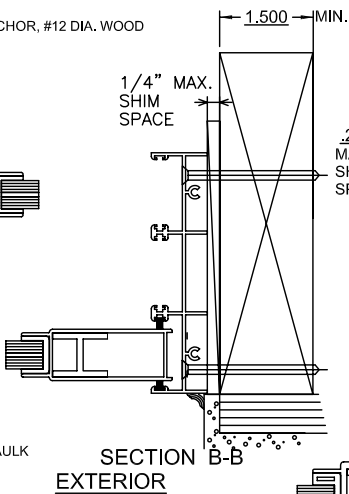

SECTION B-B
EXTERIOR

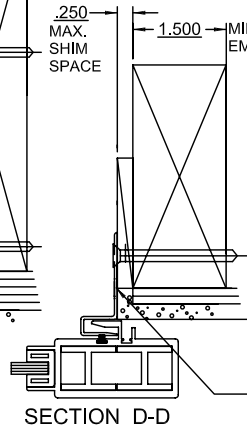

SECTION D-D

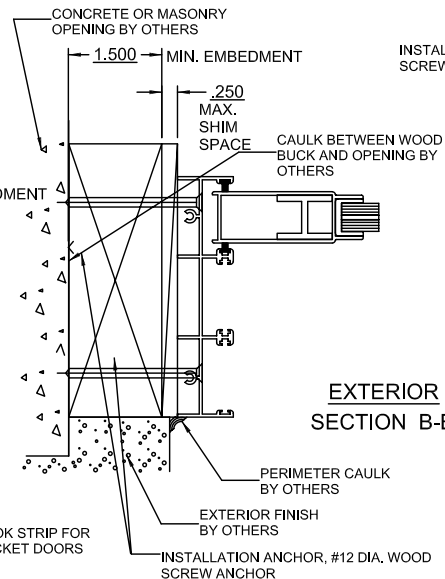

EXTERIOR
SECTION B-B

TYPICAL DETAIL AT 2 X BUCK

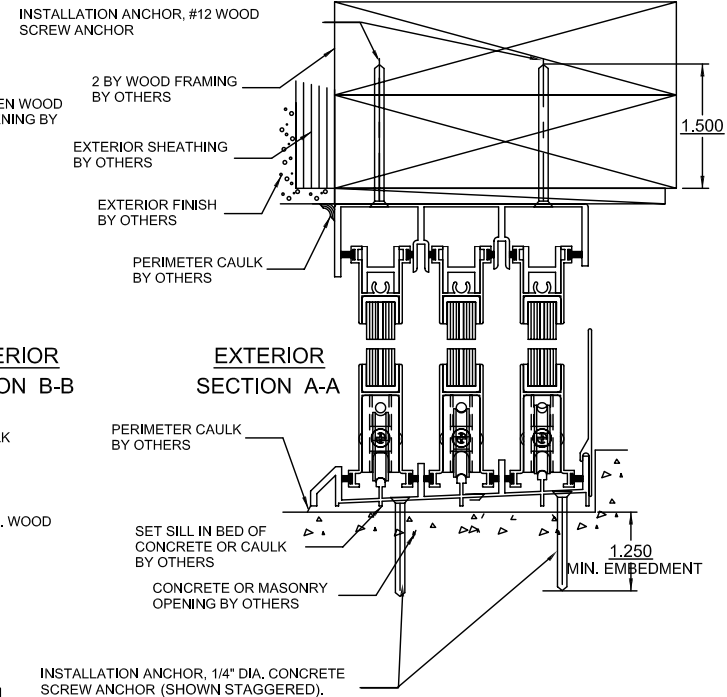

EXTERIOR
SECTION A-A

TYPICAL DETAIL AT 2 BY WOOD FRAMING

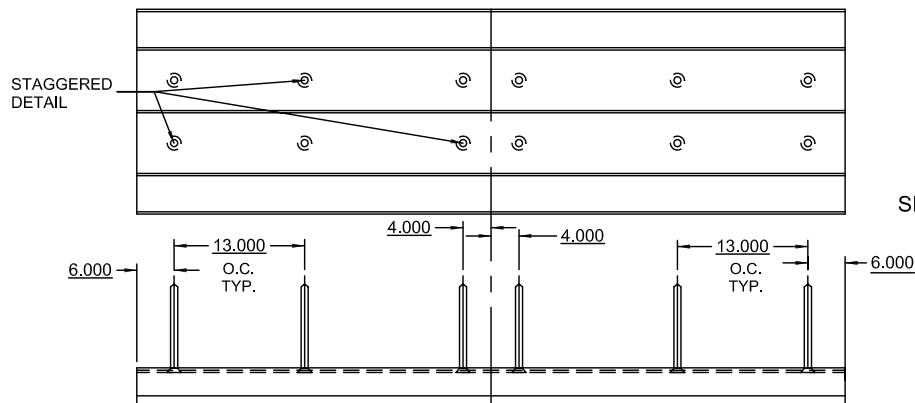

TYPICAL ANCHOR DETAIL AT INTERLOCK OR ASTRAGAL

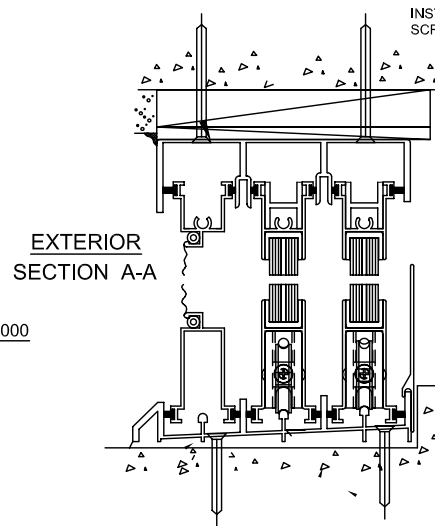

EXTERIOR
SECTION A-A

WINDOW CRAFTSMEN, INC. 6031 CLARK CENTER AVE. SARASOTA, FLORIDA 34238		
TITLE: SLIDING GLASS DOOR, SERIES 50 IMPACT WOOD FRAMING SYSTEMS INSTALLATION DETAILS		
ENGINEER: MARK A. SMITH	DRAWN BY: MAS	DATE: 12/18/08
DISCIPLINE: CIVIL	SCALE: N.T.S.	DWG. NO. WCI-SGD007
FL. REG. NO.: 55511	REV. LETTER:	SHEET 4

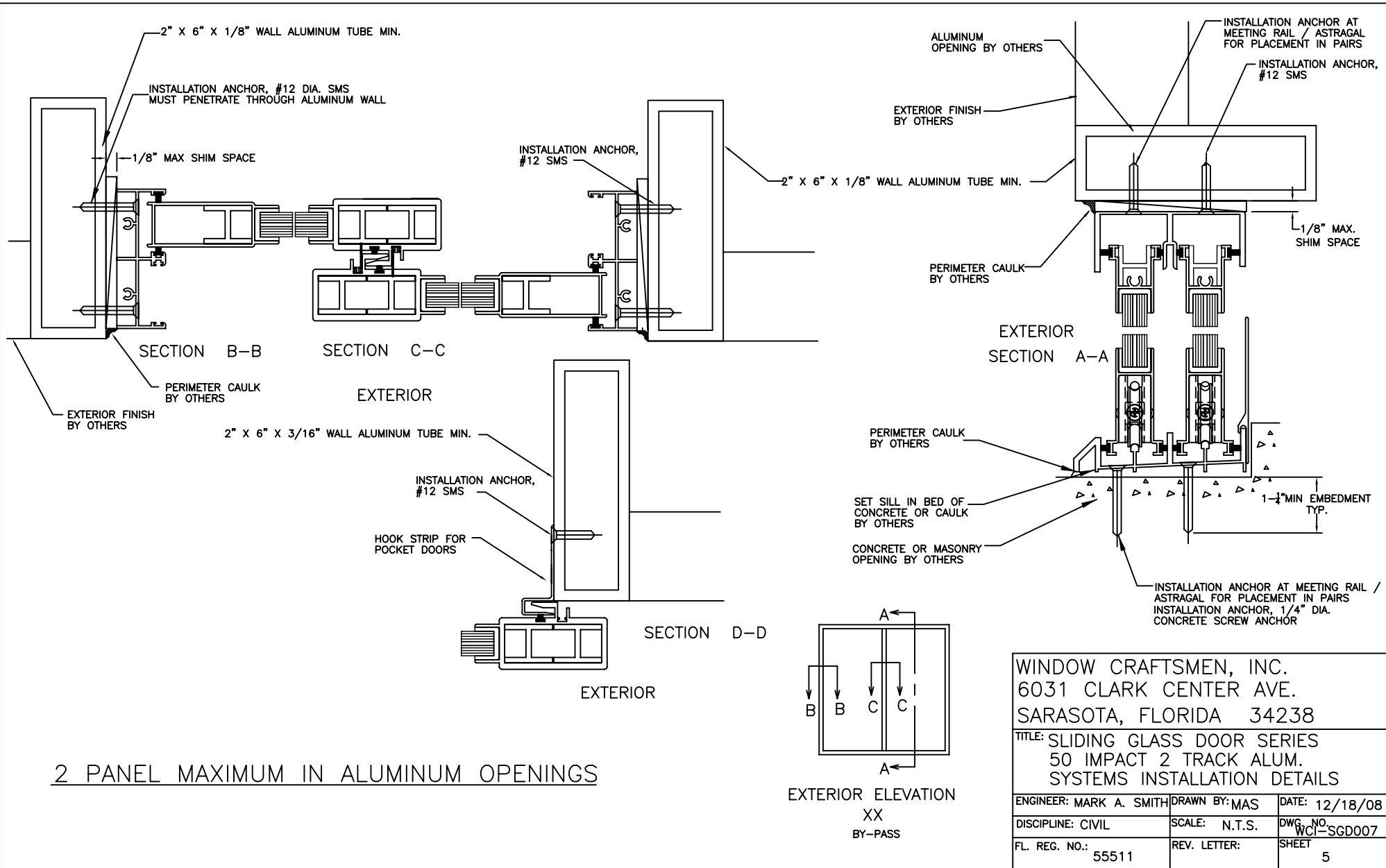

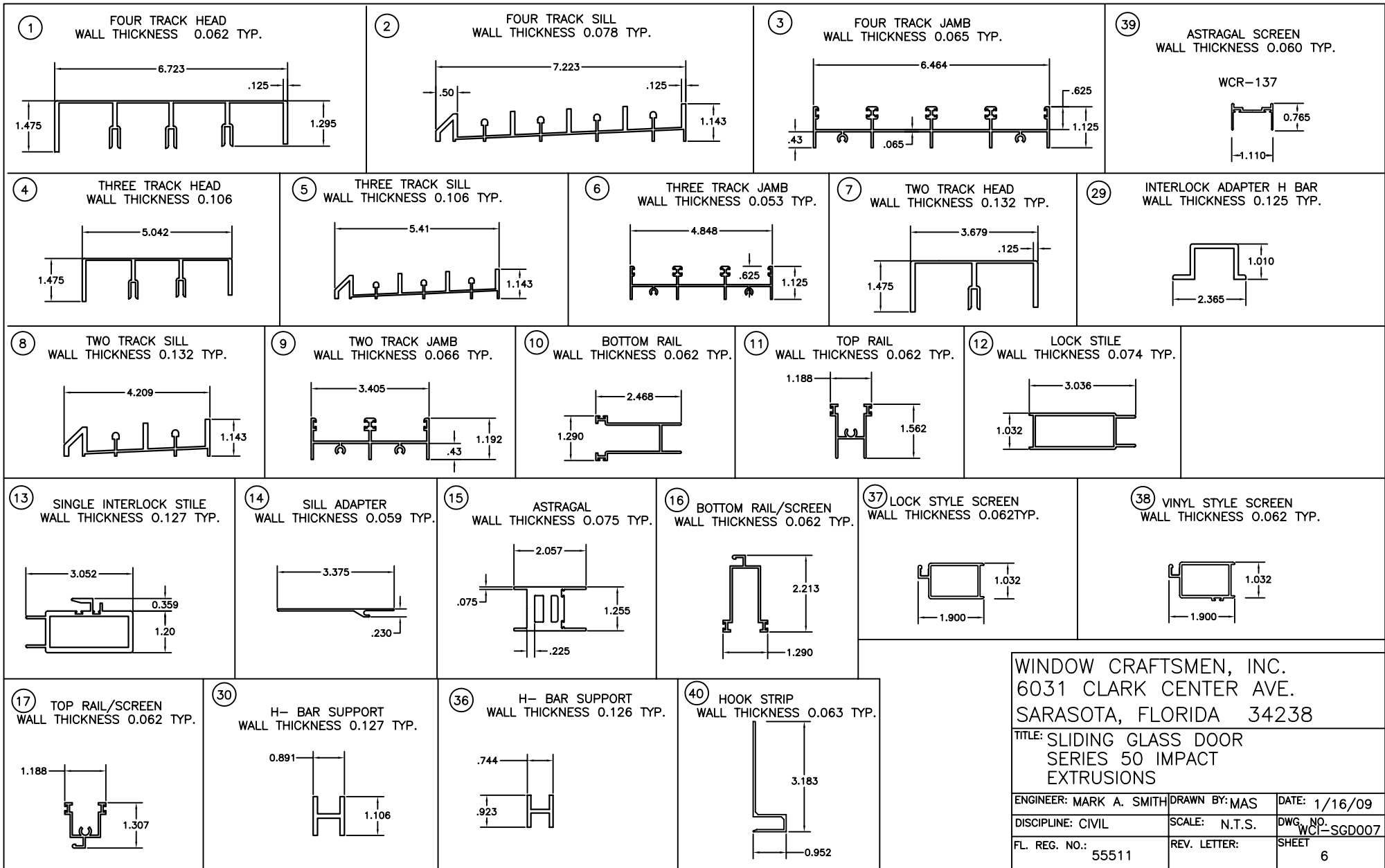

WINDOW CRAFTSMEN, INC.
6031 CLARK CENTER AVE.
SARASOTA, FLORIDA 34238

TITLE: SLIDING GLASS DOOR
SERIES 50 IMPACT
EXTRUSIONS

ENGINEER: MARK A. SMITH	DRAWN BY: MAS	DATE: 1/16/09
DISCIPLINE: CIVIL	SCALE: N.T.S.	DWG. NO. WCI-SGD007
FL. REG. NO.: 55511	REV. LETTER:	SHEET 6

BILL OF MATERIAL				
ITEM NO.	PART NO.	DESCRIPTION	VENDOR	
1	WCR-90499-1	FOUR TRACK HEAD	ALUM. ALLOY 6063-T5	PROFILE
2	WCR-90500-1	FOUR TRACK SILL	ALUM. ALLOY 6063-T5	PROFILE
3	WCR-90501	FOUR TRACK JAMB	ALUM. ALLOY 6063-T5	PROFILE
4	WCR-79670-1	THREE TRACK HEAD	ALUM. ALLOY 6063-T5	PROFILE
5	WCR-79671-1	THREE TRACK SILL	ALUM. ALLOY 6063-T5	PROFILE
6	WCR-79672	THREE TRACK JAMB	ALUM. ALLOY 6063-T5	PROFILE
7	WCR-90496-1	TWO TRACK HEAD	ALUM. ALLOY 6063-T5	PROFILE
8	WCR-90497-1	TWO TRACK SILL	ALUM. ALLOY 6063-T5	PROFILE
9	WCR-90498	TWO TRACK JAMB	ALUM. ALLOY 6063-T5	PROFILE
10	WCR-90785	BOTTOM RAIL	ALUM. ALLOY 6063-T5	PROFILE
11	WCR-91060	TOP RAIL	ALUM. ALLOY 6063-T6	PROFILE
12	WCR-110	LOCK STILE	ALUM. ALLOY 6063-T6	PROFILE
13	WCR-111	SINGLE INTERLOCK STILE	ALUM. ALLOY 6063-T6	PROFILE
14	WCR-112	SILL ADAPTER	ALUM. ALLOY 6063-T6	PROFILE
15	WCR-038A	ASTRAGAL	ALUM. ALLOY 6063-T5	PROFILE
16	WCR-114	BOTTOM RAIL SCREEN	ALUM. ALLOY 6063-T5	PROFILE
17	WCR-115	TOP RAIL SCREEN	ALUM. ALLOY 6063-T5	PROFILE
18		SPLINE, 200 ROUND SCREEN		ALUMINUM SPECIALTIES
19	WINCR-1648-01	DOOR LOCK SET		AMERBURY
20	GLASS	9/16, (1/4"HS x .090 x 1/4"HS)		CARDINAL
21	PJS-TA138-SS	TANDEM ROLLER ASSEMBLY		SULLIVAN ASSOCIATES
22	FLB229999	DOOR BUMPER		FRANK LOWE RUBBER
23	SGD-1800	PANEL BUMPER		COMMERCIAL PLASTICS
24		#14 X 1", PANEL SCREW -1		ACTION BOLT
25		#14 X 1" TYPE 23, PANEL SCREW-2		ACTION BOLT
26		8-32 X 3/8", KEEPER SCREW		ACTION BOLT
27		#12 X 1-3/4", INSTALLATION/ASTRAGAL SCREW		ACTION BOLT
28		#12 X 1-1/4" SQ. TYPE B, MAINFRAME SCREW		ACTION BOLT
29	WCR-100	INTERLOCK ADAPTER H BAR	ALUM. ALLOY 6063-T6	PROFILE
30	WCR-002A	H-BAR SUPPORT	ALUM. ALLOY 6063-T5	PROFILE
31	W23251NW	POLYPILE 0.187 X 0.250 FIN		ULTRAFAB
32	W13251NW	POLYPILE 0.187 X 0.250		ULTRAFAB
33	TP-1023	SETTING BLOCK		TEAM PLASTICS
34	TP-433	VINYL GLAZING SCREEN		TEAM PLASTICS
35	TP-915	VINYL INTERLOCK		TEAM PLASTICS
36	WCR-007	H-BAR SUPPORT	ALUM. ALLOY 6063-T6	PROFILE
37	WCR-116	LOCK STILE SCREEN		PROFILE
38	WCR-117	VINYL STYLE SCREEN		PROFILE
39	WCR-137	ASTRAGAL SCREEN		PROFILE
40	62490W13	HOOK STRIP		NUAIR
41	795802	TREMGLAZE S500		TREMCO
42	WC-118	SECURITY CLIP		RIMER & RIMER
43	PD300WHUC-S1	SCREEN HANDLE SET		SULLIVAN ASSOCIATES
44	2537-SS	KEEPER		SULLIVAN ASSOCIATES

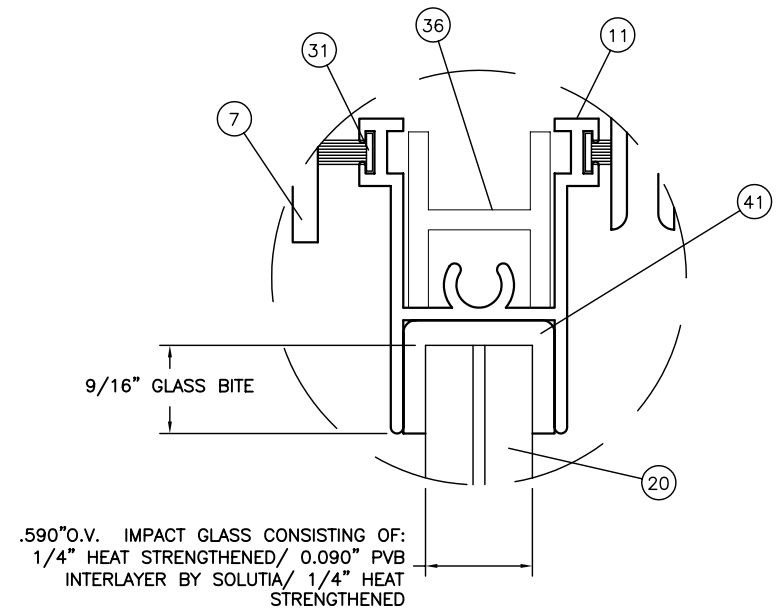

GLAZING DETAIL A

WINDOW CRAFTSMEN, INC.
6031 CLARK CENTER AVE.
SARASOTA, FLORIDA 34238

TITLE: SLIDING GLASS DOOR
SERIES 50 IMPACT
BILL OF MATERIALS

ENGINEER: MARK A. SMITH	DRAWN BY: MAS	DATE: 1/16/09
DISCIPLINE: CIVIL	SCALE: N.T.S.	DWG. NO. WCI-SGD007
FL. REG. NO.: 55511	REV. LETTER:	SHEET 7